

harman/kardon

HIGH FIDELITY CASSETTE DECK/TUNER

CH161

owner's manual



Congratulations on your purchase of a Harman Kardon CH161 High Fidelity Cassette Deck/Tuner.

To fully understand the CH161's capability, please read this manual carefully and follow all of the instructions regarding its use and installation.

Superior autosound performance is now available in a small 7" chassis that will fit nearly any car made. The CH161 is a complete full-featured unit.

CASSETTE DECK SECTION

■ Playback Frequency Response 20—20,000 Hz (± 3 dB)

■ Discrete Playback Amplifier Circuit

■ Dolby* B and C Noise Reduction

This model is capable of providing the standard Dolby B, as well as the new Dolby C noise reduction. Dolby C NR has twice the noise reduction effect of Dolby B NR, and also improves high level, high frequency response.

■ Music Search

■ Equalizer (Tape Selector) Switch

Adjusts for normal or metal/CrO₂ tapes.

■ Mechanically Assisted Tape Loading

New improved mechanism literally pulls cassette into play position.

■ Locking Fast Forward and Rewind

Locking mechanism allows hands-off F.F. and REW operation.

■ Auto Replay at End of Rewind

■ Key Off Eject/Tape End Eject

Automatically ejects the cassette when the ignition key is turned off or the tape reaches at the tape end.

* Dolby noise reduction manufactured under license from Dolby Laboratories Licensing Corporation. "Dolby" and the double-D symbol are trademarks of Dolby Laboratories Licensing Corporation.

TUNER SECTION

■ Digital Synthesized Tuning

Digital Synthesized Tuning accuracy eliminates drifting and mistuning, thereby guarantying optimum sound quality. Six AM and six FM stations can be simultaneously stored in the memory.

■ Scan Tuning

■ Memory Scan Tuning

■ High Fidelity Performance (Low Harmonic Distortion, Low noise, Wide Stereo Separation)

■ Auto Tuner Monitor

Allows monitoring tuner automatically during the fast forward or rewind modes.

■ Auto Separation & Soft Muting Control

Adjusts stereo separation and soft muting automatically during FM stereo reception for optimum reception and sound quality.

■ Pulse Noise Suppressor

Pulse Noise Suppressor Circuit is included to reduce noise caused by the automobile electrical system.

■ Local & Mono Switches

PREAMP SECTION

■ All Discrete Circuitry

■ Separate Bass and Treble Controls

■ Loudness Switch

■ Fader Control

■ Amplifier Remote Turn-on, Power Antenna, Memory Back Up and Illumination Control Leads

■ Sub Woofer Output Jacks

This feature provides a full range stereo signal that is not affected by the fader control. It provides a signal output that is ideal for use in driving a separate power amplifier and subwoofer loudspeakers.

ACCESSORIES

DIN Type—F

Sleeve (1 pc.)

Rear Bushing (1 pc.)

Rear Panel Mounting Screw (1 pc.)

Sleeve Lock Plate (2 pcs.)

Sleeve Stop Bracket (2 pcs.)

Countersunk Screw (Small) (4 pcs.)

U-shape Key (2 pcs.)

TOYOTA DIN Type

Mounting Strap (1 pc.)

Bolt with Washer (5 pcs.)

Spring Washer (1 pc.)

Countersunk Screw (Large) (4 pcs.)

Flat Washer (1 pc.)

Bolt with Washer (Long) (1 pc.)

Hex. Nut (1 pc.)

Tapping Screw (1 pc.)

Trim Frame (1 pc.)

Connector Assembly

Spare Fuse (1 pc.)

This CH161 has 2 types of installation. Follow procedures of each type installation.

DIN Type—F

First, make sure that the installing space in the dashboard is the DIN size shown below. If the space is not big enough, increase it to the size indicated below.

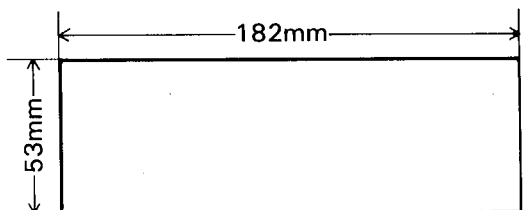

CHASSIS DIMENSIONS

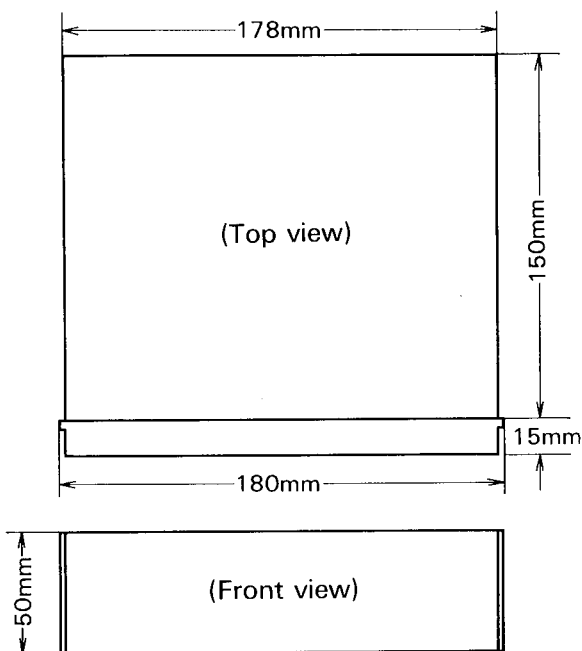

1. Remove the seal on the side of the main body, and mount the sleeve stop brackets, sleeve lock plates and rear panel mounting screw. (Fig. A)
 2. Fit the sleeve in the installing space (DIN size) on the dashboard. (Fig. B)
 3. The sleeve can be additionally secured, if necessary, by bending out the tabs around the sleeve flange. Bend them so that they hold the dashboard firmly from behind. (Fig. C)
 4. Make sure the sleeve is fixed securely, and then install the main body. (Fig. D)
 5. Use the rear bushing to fix the rear of the main body. Utilize the fitting on the installing dash backboard where provided. (Fig. E)
 6. Secure the ground lead of the unit by using a screw already attached to the chassis of the car. Attach the trim frame after the main body has been fixed. (Fig. E)
 7. Remove the trim frame before the main body is removed. After the frame is removed, insert the U-shape key to the grooves on the right and left sides of the body, and pull the body toward you while holding the right and left keys in place. (Fig. F)
- Be careful each lead wire is not damaged at this time.

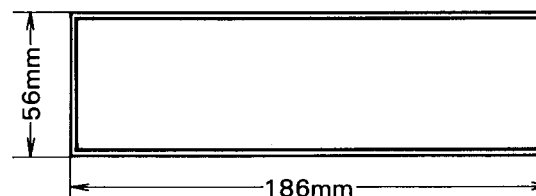

Trim Frame

Fig. 1

INSTALLATION

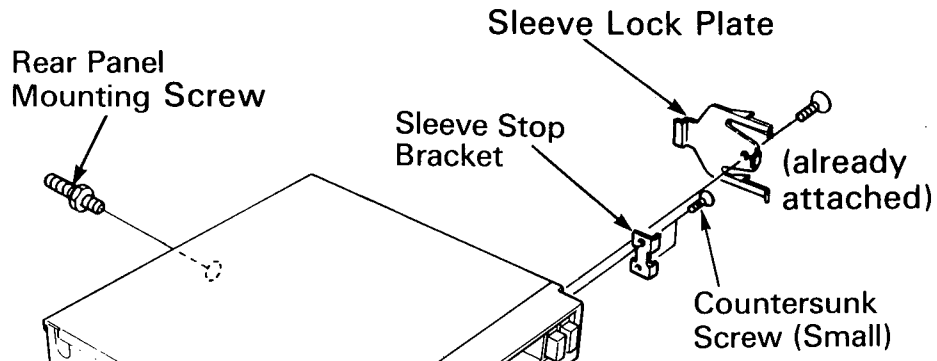

Fig. A

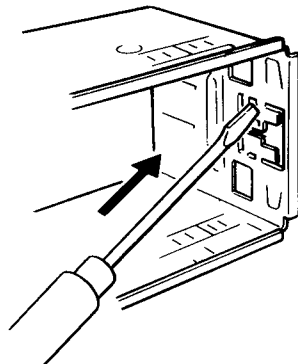
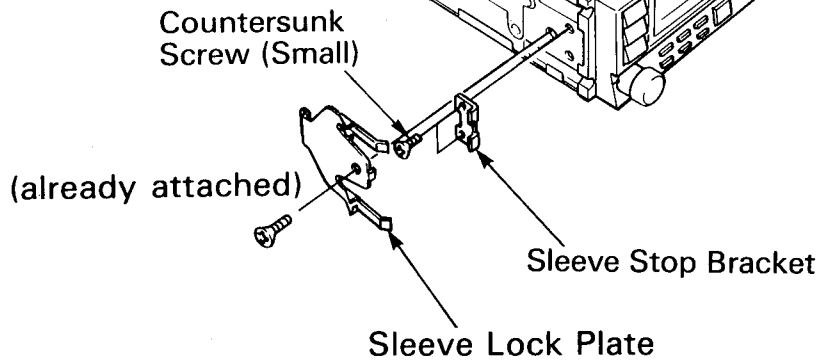

Fig. C

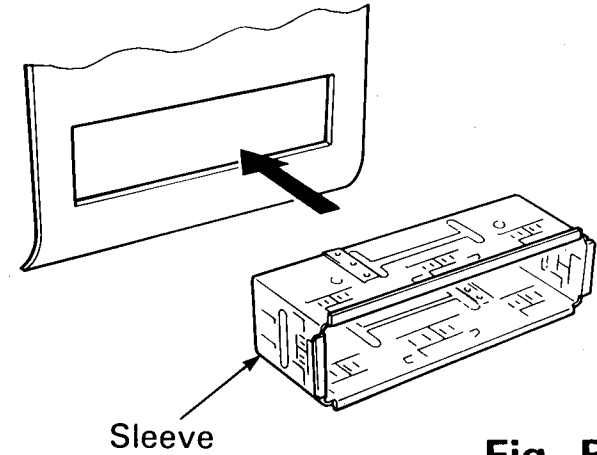

Fig. B

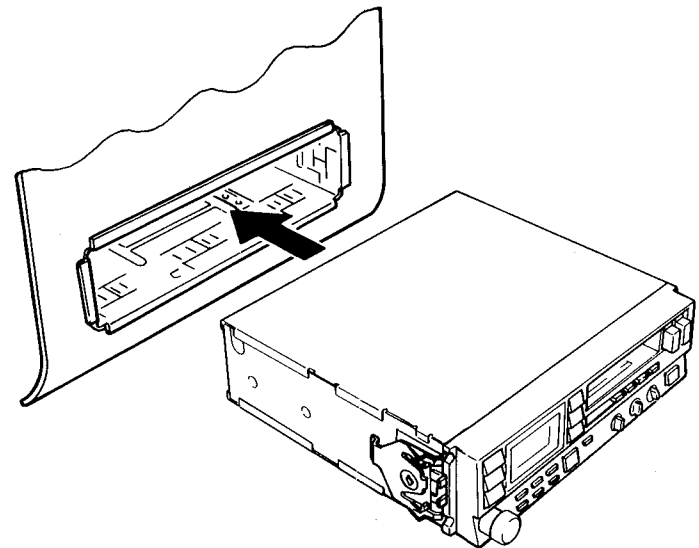
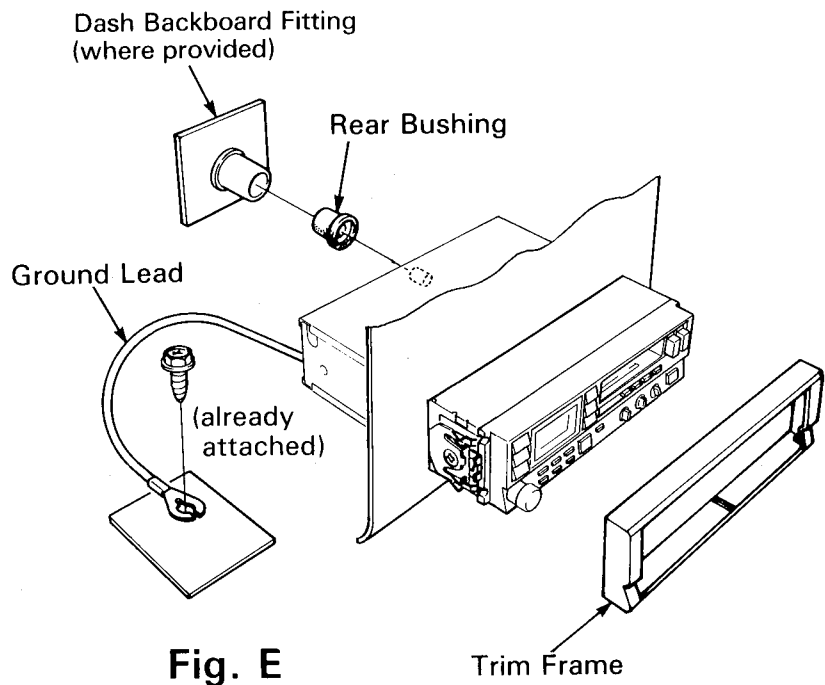

Fig. D



TOYOTA DIN Type

Fig. 2 shows the proper step procedure. Look at the diagram and make sure that you have all the necessary parts. Then, begin this procedure.

1. Secure one end of the mounting strap to the rear of the unit using the enclosed bolt. (Fig. 2-1)
2. Secure the other end of the strap to the wall using the self-tapping screw (or the Bolt and Nut). (Fig. 2-2)
3. Secure the both sides of the unit to the wall using 4 bolts with washers (or countersunk screws).
4. Secure the ground lead of the unit by using a screw already attached to the chassis of the car. Attach the trim frame after the main body has been fixed.

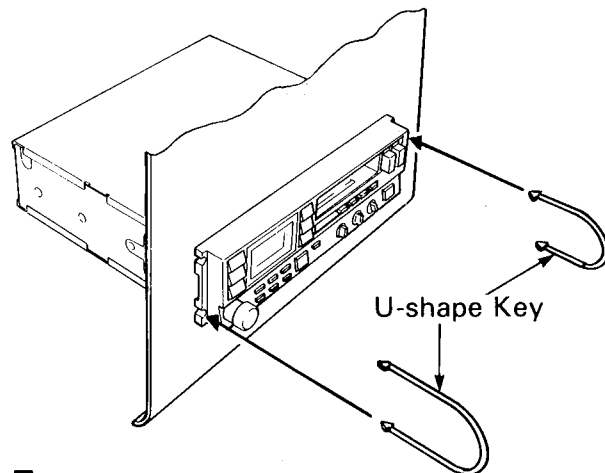

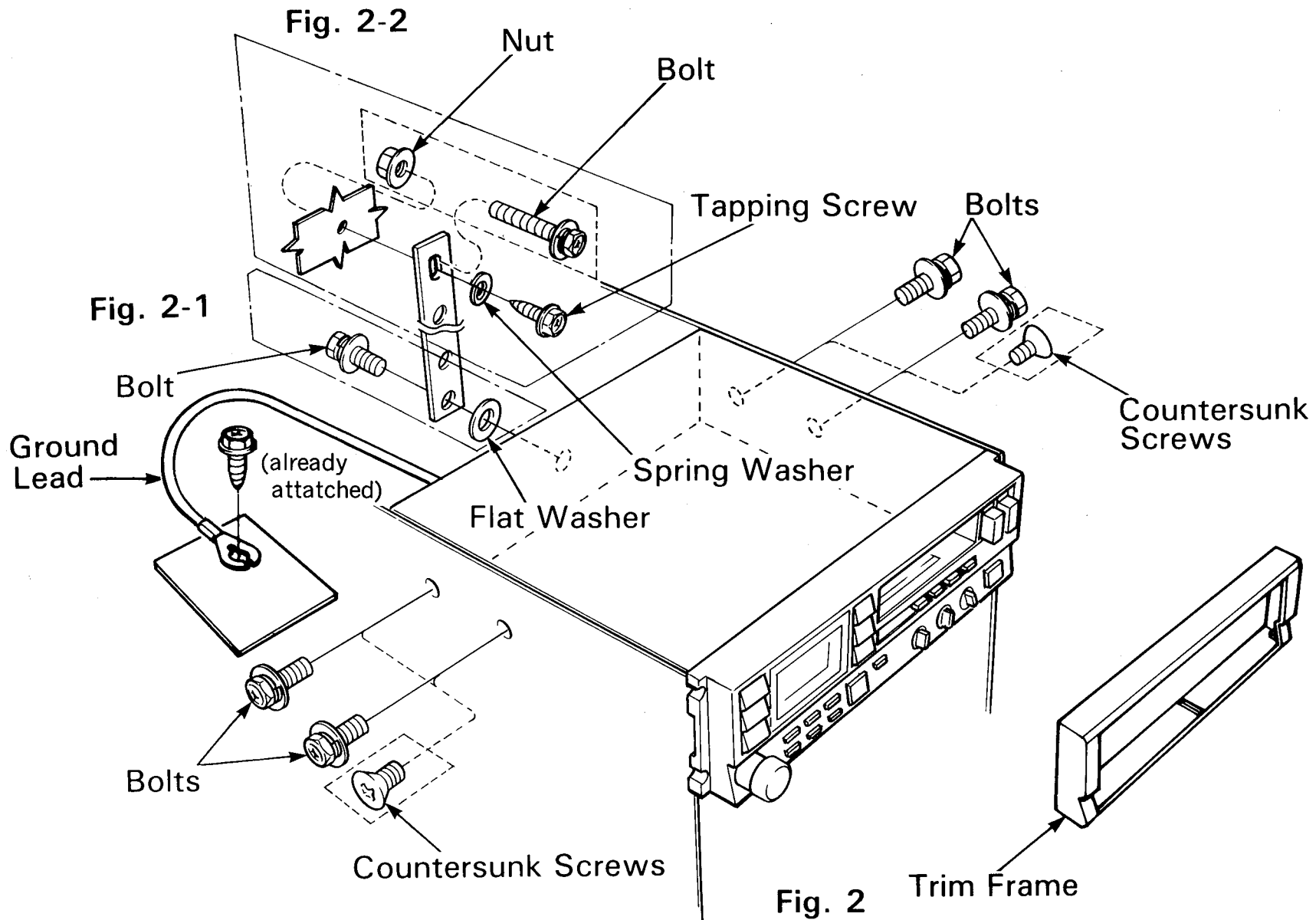

After installing all components, connect the wiring according to Fig. 3.

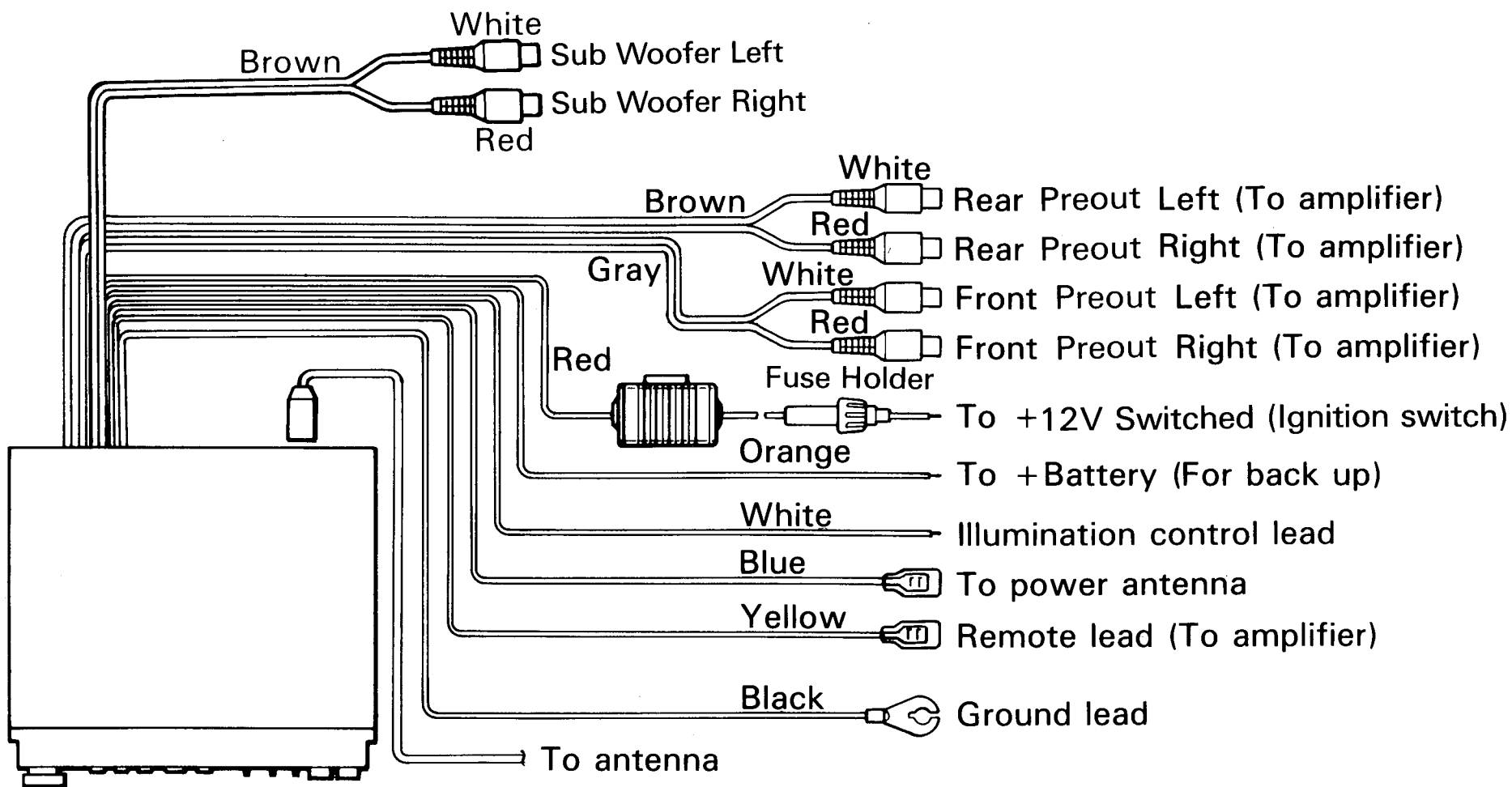

Fig. 3

+12V SWITCHED (+ACC)

The +12V SWITCHED lead is a positive power input. It should be connected to a circuit which is turned on when the IGNITION SWITCH is in the "ACC" position.

MEMORY BACK UP

The +12V MEMORY lead is a positive power input. It should be connected to a circuit which is always on in order to retain the tuner memory.

REMOTE

Connect the AMPLIFIER REMOTE turn-on lead (yellow) to the proper terminal on the amplifier, if provided.

POWER ANTENNA CONTROL

Connect the POWER ANTENNA control lead (blue) to the connector of a fully automatic power antenna. Power antenna control does not work with a semiautomatic or manually operated antenna.

ILLUMINATION CONTROL

This is the power supply cord (white) for lighting the front panel. It can be connected to the dash dimmer control, so that the front panel illumination will be similar to the dash lights. Or, it can be connected to the "+12V SWITCHED" lead, in which case the illumination will be uncontrollable.

GROUND

This is the negative power input. It should be connected directly to the car chassis.

NOTE: Be sure to secure the ground lead to a good electrical ground. Poor grounding is likely to add engine noise to the audio signals.

This unit is designed to operate with any **NEGATIVE GROUND 12V (11-16V usable) DC** electrical system.

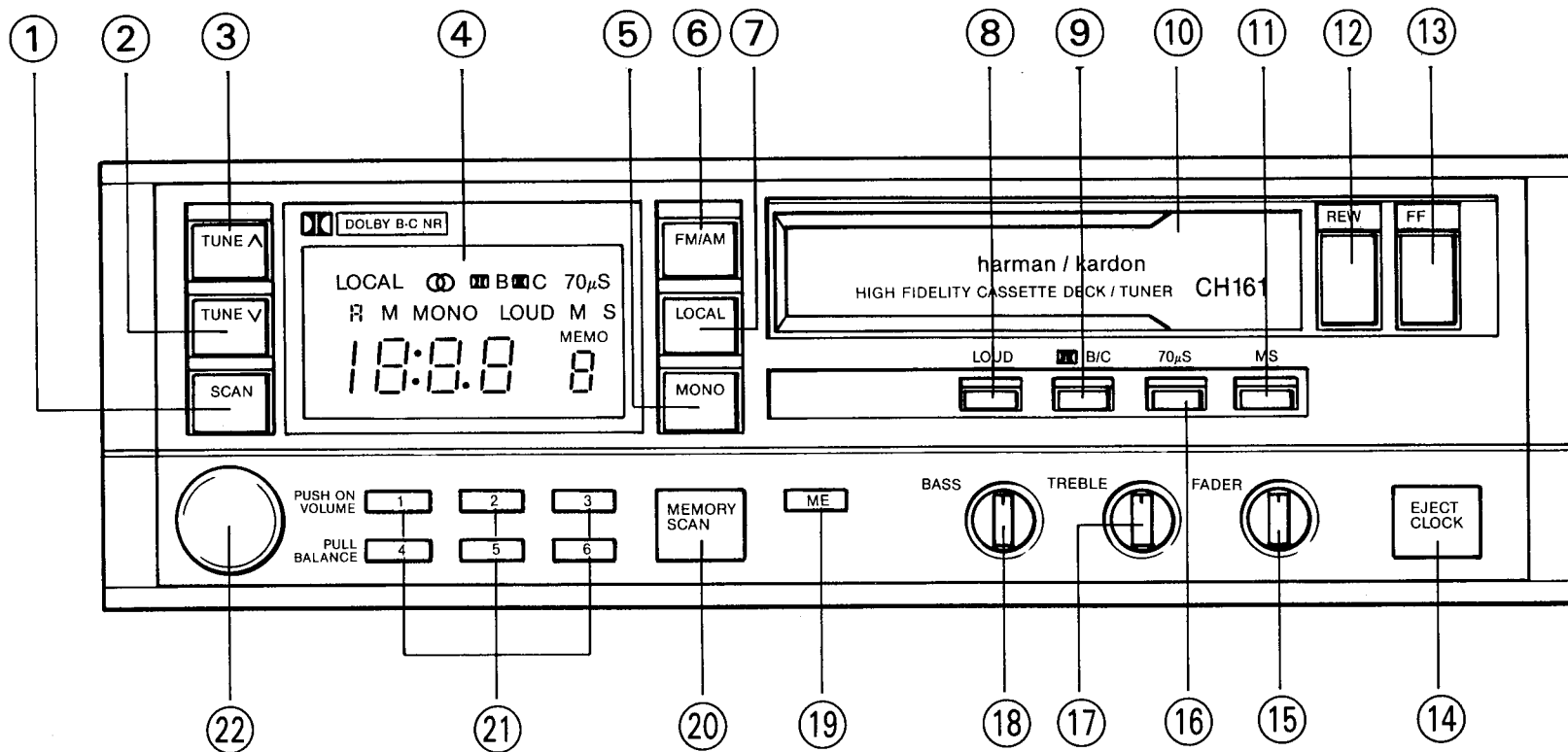

Fig. 4

1. **SCAN Button**
Push this button to operate SCAN function. (Refer to the "TUNER" section.)
2. **TUNING DOWN/CLOCK Minutes Button**
Use this button for manual tuning. When this is pressed, the tuner frequency decreases. In FM mode, frequency display moves in 200 kHz steps. In AM, the display

moves in 10 kHz steps. If this button is pressed for more than a second, the display moves quickly and continuously until released. This button also controls the minutes displayed on the clock. To set the clock (minutes) time, push the memory button first. Then push this button.

CONTROLS & INDICATORS

3. TUNING UP/CLOCK Hours Button

Use this button for manual tuning. When this is pressed, the tuner frequency increases. If this button is pressed for more than a second, the display moves quickly and continuously until released. This button also controls the hours displayed on the clock. To set the clock (hours) time, push the memory button first. Then push this button.

4. Display

This includes tuner frequency, clock, memory channel display, MS (Music Search), LOUD (Loudness), Mono, Local,  (Stereo), 70 μ S (Metal/CrO₂), Dolby B or Dolby C NR indicator.

5. MONO Switch

Mono Mode: All FM broadcasts will be received as monaural broadcasts, regardless of whether or not they are in stereo. This mode may provide quieter, more listenable sound quality under poor reception conditions.
Auto Mode: FM stereo reception is automatically selected when received at medium or high signal strength. When an FM monaural signal or a weak FM stereo signal is received, it automatically switches to the FM monaural mode.

6. FM/AM Band Select Switch



7. LOCAL-DX Selector

Press this button to change the tuner sensitivity mode (Local or DX). In areas where radio signal strength is intense, set the mode to LOCAL.

8. LOUDNESS Switch

When listening at a low level, the loudness switch will create a more natural sound by emphasizing the low and high frequency ranges.

9. DOLBY NR Type Selector

Press this button to change Dolby NR type ( B or  C indicator illuminates.) or to turn off Dolby NR.

10. Cassette Loading Slot

11. MS (Music Search) Switch

When playing a tape, push this button to operate the Music Search function before pressing F. F. or REW button.

12. REW (Rewind) Button

Press this button to rewind the tape. To operate the Music Search function, first press the Music Search button and then this button.

13. F. F. (Fast Forward) Button

Press this button to advance the tape at fast speed. To operate the Music Search function, first press the Music Search button and then this button.

14. EJECT Button/Display Mode Selector

Push this button to eject the cassette. This also changes the display mode to clock (during tuner operation). When the unit is first turned on, it will automatically display the tuner frequency. Pushing the eject button changes the display from tuner frequency to clock for 5 seconds.

CONTROLS & INDICATORS

15. FADER Control

This control adjusts the balance of front and rear level. Turn this control clockwise to decrease the front level or counterclockwise to decrease the rear level. It has center click to indicate the balance of the front and rear channels. Note that the fader control has no effect on the subwoofer output level.

16. 70 μ SEC (Tape Selector) Switch

Press when using metal or CrO2 tape.

17. TREBLE Control

This controls the high frequency sounds. Turn it clockwise to boost or counterclockwise to cut them. It has center click to indicate flat frequency response.

18. BASS Control

This knob controls the low frequency sounds. Turn it clockwise to boost or counterclockwise to cut them. It has center click to indicate flat frequency response.

19. MEMORY Button

This button is used to enter or change the preset stations or the clock setting. When this button is pressed, the MEMO indicator illuminates for 5 seconds. This indicates that the memory standby state is activated.

20. MEMORY SCAN Button

This button activates the memory scan mode. (Refer to the "TUNER" section.)

21. PRESET MEMORY Buttons

Press any one of the six Preset Memory buttons while the MEMO indicator is illuminating, and the frequency displayed is memorized at that Preset Memory button. Each button can memorize one frequency in both FM and AM bands. Once a station frequency is memorized, it can be recalled any time the same button is pressed.

22. VOLUME Control/ON-OFF Switch (push)/BALANCE Control (pull)

Push this knob to turn on the Tuner. Push again to turn it off. This knob controls the sound level. Turning clockwise increases the sound volume and turning counterclockwise decreases it. This also controls the balance of the left and right channels. Turn it to clockwise or counterclockwise to balance the sound. It has center click to indicate the balance of the left and right channels.

CLOCK

1. Press the EJECT/CLOCK button to change the DISPLAY mode from TUNER to CLOCK.
2. Press the MEMORY button. This activates the "clock setting" mode for 5 seconds.
3. To set the correct Hour, press TUNING UP during clock setting mode. Each press of the TUNING UP button will advance the clock one hour. If the button is pressed and held, the hours will advance rapidly.
4. To set the minutes, press the TUNING DOWN button during clock setting mode. Each press of the button will advance the clock one minute. If the button is pressed and held the minutes will advance rapidly.
5. When the TUNING UP (or TUNING DOWN) button is released the clock will begin counting.

CASSETTE

1. With the cassette tape opening to the right, insert the cassette into the loading slot as far as it will go. The unit is then turned ON even if the tuner is off, and the tape will begin playing.
2. If the tape is a Metal/CrO₂ type cassette, push the 70 μ SEC (Tape Selector) switch. The "70 μ S" indicator will illuminate.
3. Push the DOLBY NR switch for a tape recorded with Dolby NR to select the type of tape being used. (B or C indicator illuminates.)
4. Adjust the VOLUME, BASS, TREBLE, BALANCE and FADER controls to suit your listening preference.

5. To stop tape play, depress the EJECT button. The cassette will eject and the player will automatically change over to the Tuner mode (when the tuner is switched on).
6. The cassette will be ejected automatically when the tape reaches the end during the play or F. F. mode.

NOTE: The cassette will be ejected automatically whenever you turn the ignition switch to the "OFF" position while a cassette is playing.

Advancing the Tape Rapidly in Forward or Reverse Direction

1. Depress the F. F. or REW button until it locks and the tape will run rapidly in the designated direction. The player automatically changes over to the Tuner mode (when the tuner has been switched on) during fast winding.
2. Lightly depress the other button (F. F. or REW) to stop the fast winding mode. The tape will start playing again.

NOTE: The tape will be replayed automatically after the tape is rewound.

MS (Music Search) system

The Music Search is a system whereby the tape is fast-forwarded or rewound to the beginning of a song, and the playback operation is automatically started. However, only one song can be searched with one operation; therefore, in order to bypass any number of songs in the forward or reverse direction, repeat the operation as many times as necessary.

NOTE : The following describes those instances in which the tape that is fast forwarded or rewind does not stop at the beginning, or stops in the middle of a song :

1. When the music is very soft, e. g., classical music which is mainly pianissimo.
2. When there is sustained silence of 4 seconds or more within the recording (e. g., of a conversation or a lecture).
3. When parts of a conversation, etc., are recorded onto the tape in between songs.
4. When the interval between songs is very short or contains audible noise.
5. When the recording was made at a very low recording level.

To Search the song immediately following the one presently being played

1. Press the MUSIC SEARCH button. The Music Search indicator illuminates.
2. Then press the F. F. button. (The tape is fast forwarded to the beginning of the following song, and the playback operation is automatically started.)

To Repeat the song which is presently being played

1. Press the MUSIC SEARCH button. The Music Search indicator illuminates.
2. Then press the REW button. (The tape is rewind to the beginning of the song, and the playback operation is automatically started.)

TUNER

The tuner will not operate if a tape is inserted. Remove the tape by depressing the EJECT button.

Automatic Tuning

1. Turn the tuner on by pushing the VOLUME control knob.
2. Select AM or FM reception by pressing FM/AM Band Selector.
3. Press the SCAN button. The tuner begins to search for broadcasted signals. When a broadcasted signal is tuned in, the automatic scanning stops at that station for 5 seconds. It then moves up in frequency to the next station, etc. To stop scanning, press any of the TUNING buttons (SCAN, UP or DOWN).
4. Note that this unit can only scan up in frequency.
5. When in the auto mode (MONO indicator does not illuminate.), the stereo indicator will illuminate only when an FM stereo broadcast is being received.
6. Adjust the VOLUME, BASS, TREBLE, BALANCE and FADER controls to suit your listening pleasure.

Manual Tuning

1. Turn the tuner on by pushing the VOLUME control knob. The frequency received will be displayed.
2. Select AM or FM reception by pressing the FM/AM Band selector.
3. Select the desired station by pressing the TUNING UP or DOWN button.

4. When in the auto mode (MONO indicator does not illuminate.), the stereo indicator will illuminate when an FM stereo broadcast is being received.
5. Adjust the VOLUME, BASS, TREBLE, BALANCE and FADER controls to suit your listening pleasure.

Preset Memory Tuning

This feature enables the selection of one of six AM and six FM broadcasts by simply pressing a PRESET button. This eliminates the need for auto or manual tuning. In order to use this feature, broadcast frequencies must be entered into the PRESET memory as follows;

1. Tune to the station to be memorized by using Auto or Manual Tuning.
2. Press the MEMORY button. The MEMO display will illuminate for 5 seconds. During this period, press one of the PRESET MEMORY buttons numbered 1 through 6. The button's number will be displayed and presetting of the station is completed.
3. To cancel a memorized station and memorize a new station at that number, tune to the frequency of the new station and follow step 2 above. The old station is automatically cleared, and the new station is memorized.

Preset Memory Scan

This feature enables the scanning of the preset stations of the specified band for 5 seconds twice each. Pressing the

Memory Scan button will scan from the preset station of the lowest frequency. Press the Memory Scan button again to stop scanning.

Last Station Memory Function

This function "remembers" the frequency last received before changing bands (FM/AM). When changing the band from FM to AM and again to FM, the last received FM station will be tuned in. This function also "remembers" the frequency of the station last received before turning off the power or before changing to the cassette mode. When the power is turned on, the frequency of the station last received is displayed by the FREQUENCY Display, regardless of whether or not the station is a preset one.

PRECAUTIONS

1. Always remove the cassette tape from the unit when not in use.
2. When replacing fuse(s), the replacement must be of the same amperage as shown on the fuse holder. If the fuse(s) blow more than once, carefully check all electrical connections for shorted circuitry. Have your car's voltage regulator checked also. Do not attempt to repair the unit yourself; consult Harman Kardon or your nearest Harman Kardon Service Station for servicing.
3. In order to ensure proper performance, be sure the temperature in your car is within the range of 14°F (-10°C) to 140°F (60°C) before turning your player on. Good air circulation is essential, especially in hot weather, to prevent internal heat build-up in the unit.
4. C-120 type cassette tapes are not recommended for use in any automobile tape players.
5. Prevent any foreign objects from entering the cassette opening as the precision mechanism and tape head could be damaged.
6. When your tape is not in use, store in the case provided by tape manufacturer.
7. To protect your cassette tapes, store them in a cool place away from dust, dirt and strong magnetic sources such as electric motors and TV sets.
8. Check and make sure any slack in the tape is taken up before inserting the tape into the unit. A loose tape could cause damage to the unit and the tape itself. Tighten the cassette by inserting a pencil or a similar instrument into

the spindle hole and turn until all the slack has been taken up. (Fig. 5)

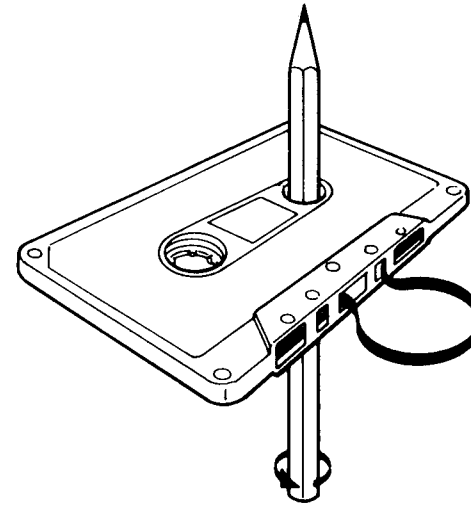

Fig. 5

CLEANING

It is recommended that the tape head be cleaned after every 10 hours of use. To do so, insert a special head cleaning cassette into the tape loading slot and allow it to run for a few minutes.

TROUBLESHOOTING CHECKLIST

Most of the problems experienced by customers are due to incorrect operation of their units. If this unit does not operate as you intended, first check the items in the checklist. Also

check other related components such as the speakers, amplifier and other electrical equipment you use with this unit.

Problem	Cause	Remedy
The tape does not run.	<ul style="list-style-type: none"> ● Tape has too much slack. 	<ul style="list-style-type: none"> ● Eject the cassette and remove tape slack. (See Fig. 5)
Sound flutters.	<ul style="list-style-type: none"> ● Tape head, capstan or pinch roller is dirty. ● Cassette tape is bad. 	<ul style="list-style-type: none"> ● Clean those parts using a special cleaning cassette. ● Use new cassette.
Unit does not play back.	<ul style="list-style-type: none"> ● Incorrect connection. ● Sound is not recorded on the tape. ● Tape head is dirty. 	<ul style="list-style-type: none"> ● Be sure all connections. ● Exchange with a recorded tape. ● Clean the tape head.
Sound is distorted.	<ul style="list-style-type: none"> ● Tape head is dirty. ● Incorrect setting of the 70 μSEC SWITCH. 	<ul style="list-style-type: none"> ● Clean the tape head. ● Set 70 μSEC SWITCH according to the type of tape.
High frequency sound is not clear.	<ul style="list-style-type: none"> ● Tape head is dirty. ● Incorrect operation of DOLBY NR or 70 μSEC SWITCH. 	<ul style="list-style-type: none"> ● Clean the tape head. ● Set the switch correctly.
Broadcast cannot be heard.	<ul style="list-style-type: none"> ● The tape is running. ● Incorrect connection of the antenna. 	<ul style="list-style-type: none"> ● Eject the cassette. ● Check the antenna connection wire.
AM sound is noisy.	<ul style="list-style-type: none"> ● The unit is effected by the amplifier. 	<ul style="list-style-type: none"> ● Move the amplifier to a location farther away from the antenna.
Sound has ignition noise.	<ul style="list-style-type: none"> ● Poor connection of ground. ● Poor power line filtering. 	<ul style="list-style-type: none"> ● Be sure to secure ground lead. ● Add a power line filter to the + 12V Switched wire.

SPECIFICATIONS

CASSETTE DECK SECTION

Frequency Response (Harman/Kardon Test Tape, ± 3 dB, Dolby NR off)	: 20—20,000 Hz
Wow and Flutter (WRMS)	: 0.09%
Signal to Noise Ratio (Cr02) Dolby NR off	: 54 dB
Dolby B NR	: 64 dB
Dolby C NR	: 72 dB

TUNER SECTION

Type of Tuning	: Digital Synthesized
Antenna Terminal Impedance	: 75 Ohms

—FM—

Usable Sensitivity (Mono)	: 14.8 dBf ($1.5\mu\text{V}$ —75 Ohms)
50dB Quieting Sensitivity (Mono)	: 18 dBf ($2.2\mu\text{V}$ —75 Ohms)
Signal to Noise Ratio (65 dBf) Mono	: 72 dB
Stereo	: 68 dB
Alternate Channel Selectivity	: 70 dB
Stereo Separation (1kHz, 65dBf, 100% Modulation)	: 40 dB
THD (1 kHz, 65 dBf) Mono	: 0.2%
Stereo	: 0.4%
Capture Ratio	: 1.5 dB
IF Rejection	: 80 dB
Image Rejection	: 55 dB
Frequency Response (± 3 dB)	: 30—15,000 kHz

—AM—

Sensitivity	: $30\mu\text{V}$
Alternate Channel Selectivity	: 50 dB

AUDIO SECTION

Tone Control BASS (at 50 Hz)	: ± 10 dB
TREBLE (at 10 kHz)	: ± 10 dB
Loudness Control (at 80 Hz)	: +10 dB
Preout Output Level (10 k Ohms Load)	: 0.8 V
Preout Output Impedance	: 500 Ohms
Negative Feedback	: 22 dB

GENERAL

Dimensions Chassis (W×H×D)	: 7"×2"×5-7/8" (180×50×150 mm)
Weight	: 3 lbs. (1.4 kg)
Power Supply	: DC 13.8V (11—16 V Usable), Negative Ground
Current Consumption	: 0.6 A

All specifications and features subject to change without notice.